

## Multi-functional Integrated Optical Circuit Package (MIOC-SM-18)

### Overview

**MIOC-SM-18** is a key component in Fiber Optic Gyroscope (FOG) for measuring angular velocity of an inertial navigation system. This integrated device, fabricated on Lithium Niobate ( $\text{LiNbO}_3$ ) material, is composed of a polarizer, a Y-junction coupler and dual electro-optical phase modulators. Waveguides on the chip are produced by the High Temperature Proton Exchange (HTPE) process. The MIOC (chip) has more than 60dB Polarization Extinction Ratio (PER) and can minimize bias drift resulting from polarization crosstalk induced non-reciprocity. The package of this MIOC can be customized to meet the need of different applications.

### Key Features

- $1550 \pm 20$  nm operation
- PM fiber input and output port
- $V_{\pi}$  voltage  $< 4.2$  V
- Fiber/chip crosstalk  $< -20$  dB
- Low insertion loss  $\leq 3.5$  dB
- Push-pull electrode design

### Applications

- Fiber Optic Gyroscope (FOG)
- Fiber Optic Current Sensor (FOCS)
- Hydrophone
- CubeSat and SmallSat
- Other Optical Sensing Applications

### Application Diagram

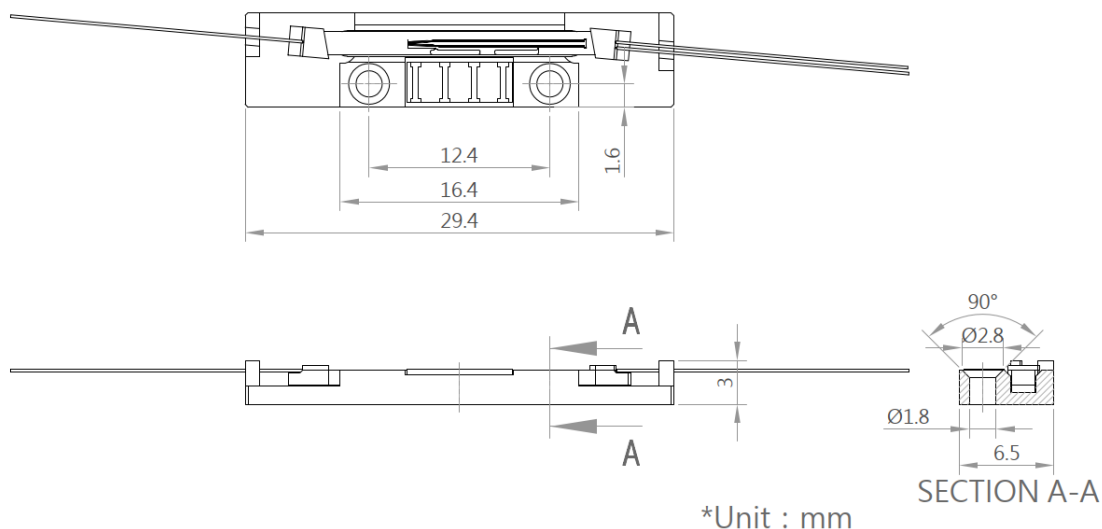

## Specifications

Model	MIOC-SM-18
Operating Wavelength	1550 ± 20 nm
Pigtailed Insertion Loss	≤ 3.5 dB
Split Ratio	50 ± 3%
Half-wave Phase Modulation Voltage, $V_{\pi}$	< 4.2 V
PM Pigtail Crosstalk	≤ -20 dB
Intensity Modulation	≤ 0.1 % typ.
Electrode Type	Push-pull
Maximum Input Voltage	+/- 15 V
Operating Temperature	-35°C to + 70°C
Product Size	29.4 x 6.5 x 3 mm
Housing Material	Stainless Steel
Input/Output Fiber Type	Corning RC PM15 80µm cladding diameter
Fiber Length	0.6m (customizable)
Fiber Orientation	Slow Axis aligned to TE Mode
Substrate Material	LiNbO <sub>3</sub>
Crystal Orientation	X-cut, Y-propagation
Waveguide Process	Proton Exchange

## Simple Functional Drawing

